

Helvar ballast and ignitors are designed to be built into luminaires. Safe and reliable operation of the components requires that the luminaire complies with the relevant standards and regulations (e.g. IEC 60598-1). The luminaire shall be designed to adequately protect the control gear from dust, moisture and pollution.

The luminaire manufacturer remains responsible for the correct choice and installation of the control gear according to the application. Specifications of the control gear shall not be exceeded when it is used in the luminaire in the actual operating conditions. The ballast shall not be used outside the luminaire.

Wiring considerations

1. Fluorescent and HID (High Intensity Discharge) lamp ballasts

Wire type

- **Push in terminals:** Solid core conductor only
- **Screw terminals:** Solid core or stranded conductor

Wiring insulation According to recommendations in EN 60598

Wire cross section dimensions

- **Push in terminals:** 0.5 - 1.0mm² (0.5 - 1.5mm² for HID lamp ballasts)
- **Screw terminals:** 1.5 - 3.0 mm²

Wire preparation

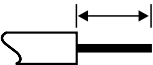
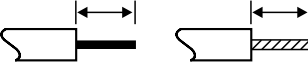
- **Push in terminals:** Strip length 8.0 - 9.0mm 
- **Screw terminals:** Strip length 7.0mm ± 1mm 

Wire connections As shown on the ballast label and the Wiring Diagram datasheets

Mineral insulated cable Not advised

Wire release from ballast

- **Push in terminals:** Use a 1mm² solid pin (or similar)
- **Screw terminals:** Flat blade screwdriver

More detailed release instructions on page 52

Wiring layout

- Keep all wiring as short as possible
- Mains wiring and lamp should always be kept as far as possible from each-other
- Mains wiring should not be bunched together with lamp wiring
- Avoid wiring 'loops' (to minimise magnetic coupling effect)
- Avoid long parallel cable runs

2. Ignitors for HID lamps

Wire type Solid core or stranded conductor

Wiring insulation According to recommendations in EN 60598

Wire cross section dimensions

- 1.5 - 3.0 mm² or 2.0 - 4.0 mm² (depending upon ignitor type)
- 2.5 - 5.0 mm² (1000W ignitors)

Wire connections As shown on the ignitor label and datasheet

Mineral insulated cable Not advised

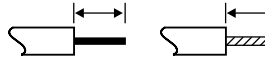
Wire preparation Strip length 7.0mm ± 1mm 

Wire release from ignitor Flat blade screwdriver

Wiring layout Keep wiring from the ignitor to the lamp as short as possible

Installation & operational considerations

Ballast earthing

- Required for safety

Lifetime

- Reliable operation and lifetime is only guaranteed if the maximum winding temperature of $tw\ 130^{\circ}\text{C}$ is not exceeded under the conditions of normal use

Ballast mounting

- The ballast must be located in such a position as to ensure that its maximum winding temperature of $tw\ 130^{\circ}\text{C}$ is not exceeded under the conditions of normal use
- Mount the ballast against a flat surface to ensure good heat dissipation

Starting aid

- For reliable starting (and electrical safety) all metal parts of the fitting must be at the same electrical potential as the ballast case

Fitting components

- Ensure the correct electrical ratings for the lamps being used

Ignitor choice

- Helvar ballasts for Metal Halide or High Pressure Sodium lamps are only suitable for use with superimposed pulse type ignitors
- Pulsar type ignitors (where a high starting voltage is applied to the ballast windings) are not suitable for Helvar ballasts. If used, the ballast winding insulation will be subjected to increased load. This will drastically shorten the ballast lifetime

Reflector position

- Situating a reflector or metal plate very close to the lamp may increase RFI emissions and cause excessive leakage current of the fitting

Protection against lamp rectification

- Metal Halide & High-Pressure Sodium lamps can begin to rectify as they reach the end of their operational lifetime. This can cause excessive temperature in a fitting. As such, it is recommended that thermal protection be fitted in these luminaires
- A thermal protection device should be fitted inside the luminaire
- Helvar ballasts for Metal Halide & High-Pressure Sodium lamps are available also with internal thermal protectors (P-types)
- Use of ignitors with a timer facility also provide some protection against lamp rectification. Use in conjunction with a thermal protector

Noise avoidance

- Ensure the ballast is securely fixed within the luminaire
- Fix the ballast at a minimum distance of 3mm from the side of the fitting
- Ensure that the fitting is of rigid construction (especially at the point where the ballast is fitted)
- In large fittings the ballast should be separated from the fitting by mounting it on an aluminium plate (approx. 2mm thick)
- Mount as few ballasts as possible in one fitting
- If using multiple ballasts in a fitting, ensure that the ballasts are mounted as far as possible from each other

Site considerations

Mixed technology on the same electrical circuit

- Magnetic and electronic ballasts should not be connected to the same electrical circuit. The energy spikes produced by magnetic ballasts may result in damage to the electronic ballasts

Miniature Circuit Breakers

- 'Type C' MCB's having trip characteristics in accordance with EN 60898 are recommended.
- 'Type B' MCB's are not recommended due to their sensitivity. If used, they must only be loaded to 60% of the equivalent 'Type C' MCB

Helvar ballast and ignitors are designed to be built into luminaires. Safe and reliable operation of the components requires that the luminaire complies with the relevant standards and regulations (e.g. IEC 60598-1). The luminaire shall be designed to adequately protect the control gear from dust, moisture and pollution.

The luminaire manufacturer remains responsible for the correct choice and installation of the control gear according to the application. Specifications of the control gear shall not be exceeded when it is used in the luminaire in the actual operating conditions. The ballast shall not be used outside the luminaire.

Wiring considerations

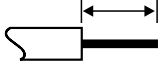
Wire type	Solid core conductor only
Wire cross section dimensions	0.5 - 1.5mm ² (EL-s-u 0.5 - 0.75mm ²)
Wiring insulation	According to recommendations in EN 60598
Maximum wire lengths	See Characteristics table (page 43)
Wire connections	As shown on the ballast label and the Wiring Diagram datasheets
Wire preparation	Strip length 7.5mm ± 1mm 
Wiring capacitance	80pF / metre (max. for advised wire lengths)
Wire insertion force	8 Newtons (typical)

Wire release from ballast (See detailed release instructions on page 52)

Wiring layout

- Keep all wiring as short as possible (particularly the 'Hot' wires - see Wiring Diagrams datasheets)
- 'Hot' wires should be of equal length
- 'Cold' wires should be of equal length
- Always run mains wiring, lamp wiring and low voltage control wiring separate from each other
- Do not run hot and cold lamp wires bunched together
- Lamp wires of two or more separate ballast should not be run together

Installation & operational considerations

Ballast earthing

- EL-s and EL-TCs ranges are in principle suitable for both Class I & II fittings (no earth required). However EMC and temperatures should be checked case by case.
- All other Helvar electronic ballasts require a protective earth to be connected to ensure reliable operation

Maximum t_c temperature

- Reliable operation and lifetime is only guaranteed if the maximum t_c point temperature is not exceeded under the conditions of use

Frequent switching

- Helvar warm start ballasts may be used in conjunction with occupancy sensors (PIR) as long as the 'on' period is greater than 20 minutes. Shorter switching period may reduce lamp life

Master / Slave connection

- Not advised

Switching off one lamp via lamp wires

- Not permitted

Starting aid

- For a reliable lamp ignition the use of metal starting aid is recommended
- For reliable starting (and electrical safety) all metal parts of the fitting must be at the same electrical potential as the ballast case

Reflector position

- Situating a reflector or metal plate very close to the lamp may increase RFI emissions and cause excessive leakage current of the fitting
- See lamp standards for recommendations

Fitting components

- Ensure the correct electrical ratings for the lamps being used (e.g. 500V rated lampholders are required for T5 lamps)

Ballast mounting position

- Ensure that the entire length of the ballast is against a flat surface to ensure good heat dissipation

Instructions for use - Electronic ballasts

Installation & operational considerations

Class II luminaires:

Helvar electronic ballasts can be used in suitably designed class II luminaires. The following points must be very carefully noted:

- EL-sc and EL-si ballasts must have functional earth connected
- Luminaire standard EN 60598 provides full details of the requirements for class II luminaires
- Starting aid may be required for reliable operating and EMC performance

Lamp “burn in”:

Brand new lamps may occasionally have an uneven distribution of internal gases. This can lead to unreliable starting or uneven light distribution from the lamp. Helvar recommend that new lamps are operated at full output (“burnt in”) for a number of hours prior to being dimmed.

DALI controls:

The DALI standard only currently governs ballast compatibility. For other units, like sensors and control devices, the compatibility assurance is in process. Until the standard for these is finalised, the total system compatibility must be ensured at the system design stage.

Stand-by function

The stand-by function is designed specifically as a protection for the ballast. It will switch the lamps off when an ‘end of lifetime’ condition occurs. Lamps can also fail in many other ways. As such, the exact operating state of the ballast under other lamp fault conditions depends on the specific failure. The ballast will not be harmed under any normal lamp failure condition. Ballasts can be reset from stand-by either by switching the mains supply off and then on, or by replacing the faulty lamps.

Lamp ‘end of lifetime’

- **Behaviour of the ballast at end of lamp life time: IEC 61347-2-3 17.2.**
- If the lamp electrical characteristics (e.g. lamp voltage) exceed the ballast internal preset values, the ballast will recognise that a lamp/s has reached the end of its useful operational life. The ballast will then switch off the supply to the lamps to prevent unnecessary stress to the circuit.

Emergency inverter units

Due to our continuing program of product development and improvement, Helvar ballast designs are evolving constantly. This natural evolution may affect compatibility between our electronic ballasts and emergency conversion modules. It is therefore the responsibility of either the fitting manufacturer, emergency unit supplier and/or system integrator to ensure the used combination is fully compatible.

Emergency inverter unit recommendations

- Use a 4 pole changeover device, with all 4 poles being used to disconnect the lamp.
- Disconnect the mains supply from the ballast before disconnecting the emergency lamp, and prior to the lamps connection to the emergency unit.
- Reconnect the emergency lamp to the ballast before applying the mains supply.
- For multiple lamp ballasts, the wiring lengths for emergency and non-emergency lamps should be equal.

Site considerations

Insulation resistance testing on an installation

- Carry out insulation resistance testing with the fittings disconnected from the mains supply (the fitting has already been tested by the manufacturer)
- If fittings are connected to the mains supply during an insulation resistance test, all Live phases and Neutral must be connected together before the test is carried out.
- Ensure correct re-connection before the mains supply is re-applied.

Mixed technology on the same electrical circuit

- Do not mix magnetic and electronic ballasts on the same electrical circuit. The energy spikes from magnetic ballasts may damage electronic ballasts.

Infra-red (IR) system

- Fluorescent lamps emit not only visible light, but also infra-red light. In some cases this may cause interference to IR systems. To minimise problems the IR system should have a reduced receiving area. To guarantee successful functionality the manufacturer of the IR system should be contacted prior to installation. Helvar ballasts typically operate at frequencies rarely used in IR applications.

3-phase supplies

- Do not apply power to the ballast / fitting without the Neutral conductor connected.
- Do not disconnect the Neutral conductor unless the supply is off.

Miniature Circuit Breakers (Please refer page 50.)

- ‘Type C’ MCB’s with trip characteristics in according to EN 60898 are recommended.
- ‘Type B’ MCB’s are not recommended due to their sensitivity. If used, load only to 60% of the equivalent ‘Type C’ MCB.

Switch-Control Information

Switch-Control provides ON/OFF switching and UP/DOWN dimming functionality from one or more simple switches. Switch-Control can be used together and simultaneously with other compatible control devices.

- EL-si ballasts, Helvar Minisensor and DALI control.
- EL-sc ballasts and analogue 1-10V control.

Suitable switch:

- Automatic return type. Mains rated (Mains is still present at the ballast terminals if the lamps are switched off from Switch-Control).
- The switch should withstand a short circuit current of:
 - 25mA per ballast (EL-si) or
 - 0.2mA per ballast (EL-sc)

Connection:

- EL-sc ballasts: Between the Switch-Control input and N (or L).
- EL-si ballasts: To the DIGIDIM input.
- Wire length: 200m maximum.
- Ballasts per switch: 50 (observe above).
- Ensure all ballasts and associated switches are connected to the same mains phase.

Operation:

- **Switch off:** Short push of the switch (<0.4 second).
- **Switch on:** Short push of the switch (<0.4 second).
 - Re-strike within 3 seconds of switch off is prevented to ensure optimal lamp warm start.
 - EL-si ballasts will switch on to the last set level.
 - EL-sc ballasts will switch on to the analogue control set level.
- **Dimming:** Long push of the switch (>0.5 second).
 - If lamps are off, the ballast dims up from minimum.
 - If lamps are on, the ballast dims in the opposite direction to previously.

Regaining analogue control (EL-sc only) when Switch-Control is active:

- Dim the analogue control device from min. to max. and back to minimum within 1 second.

Correction of out of sequence operation:

- Switch the mains supply off and on, or...
- Long push (until all lamps are on), then a short push (all lamps off), then wait 3 seconds and switch on (short push).

Compatibility:

Some ballasts manufacturers have functionality similar to Helvar Switch-Control. In most cases these methods are NOT COMPATIBLE with each other.

Connection to EL-sc ballast

- Between the Switch-Control input (pin1) and L (or N).

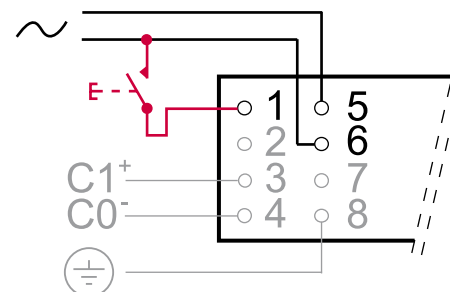

Connection to EL-si ballast

- To the DIGIDIM input.

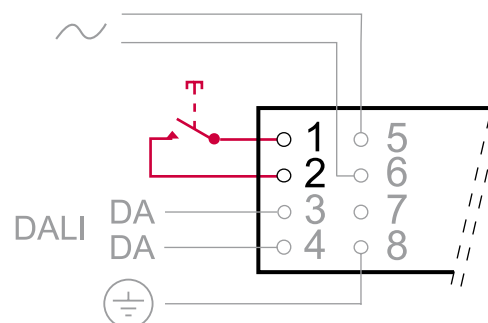

Quantity of ballasts for miniature circuit breakers (MCB's), standard ballasts

Type C MCB's are strongly recommended to use with fluorescent lighting.

- Other types can prove unsuitable due to their tripping properties.
- Practical quantities will depend strongly on the reactance of the actual circuit.

Conversion table for other types of Miniature Circuit Breaker	
MCB type	Relative quantity of ballasts
B 10A	37 %
B 16A	60 %
B 20A	75 %
C 10A	62 %
C 16A	100% (see tables)
C 20A	125 %

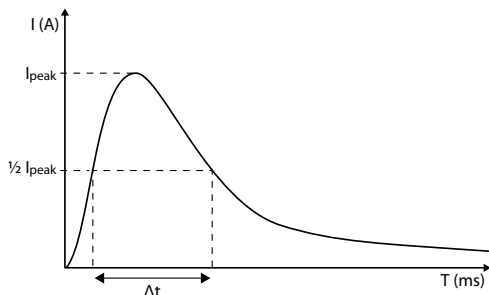

Lamp(s)	EL-s	Quantity of ballasts per miniature circuit breaker 16 A Type C		Typical inrush current I _{peak} (A)	1/2 value time Δt (μs)	Calculated energy I _{peak} ² Δt (A ² s)
		Based on I _{Cont}	Based on I _{peak}			
1 x 14 W T5	EL1x14-35s	166	122	17	69	0.16
2 x 14 W T5	EL2x14-35s	83	47	34	149	1.30
3 x 14 W T5	EL3/4x14s	56	47	34	149	1.30
4 x 14 W T5	EL3/4x14s	42	42	34	149	1.30
1 x 21 W T5	EL1x14-35s	112	47	34	149	1.30
2 x 21 W T5	EL2x14-35s	57	47	34	149	1.30
1 x 28 W T5	EL1x14-35s	86	47	34	149	1.30
2 x 28 W T5	EL2x14-35s	43	43	34	149	1.30
1 x 35 W T5	EL1x14-35s	68	47	34	149	1.30
2 x 35 W T5	EL2x14-35s	34	34	34	149	1.30
1 x 24 W T5	EL1x24s	103	103	17	69	0.16
2 x 24 W T5	EL2x24s	53	53	17	69	0.16
3 x 24 W T5	EL3/4x24s	35	32	47	165	2.67
4 x 24 W T5	EL3/4x24s	27	27	47	165	2.67
1 x 39 W T5	EL1x39s	61	61	17	69	0.16
2 x 39 W T5	EL2x39s	32	32	34	149	1.30
1 x 49 W T5	EL1x49s	49	47	34	149	1.30
2 x 49 W T5	EL2x49s	25	25	47	172	2.77
1 x 54 W T5	EL1x54	44	44	34	149	1.30
2 x 54 W T5	EL2x54	22	22	47	165	2.67
1 x 80 W T5	EL1x80s	30	30	34	149	1.30
2 x 80 W T5	EL2x80s	15	15	67	231	6.74
1 x 18 W T8	EL1x18s	143	122	17	69	0.16
2 x 18 W T8	EL2x18s	75	75	17	69	0.16
3 x 18 W T8	EL3/4x18s	50	47	34	149	1.30
4 x 18 W T8	EL3/4x18s	37	37	34	149	1.30
1 x 36 W T8	EL1x36/40/18s	74	74	17	69	0.16
2 x 36 W T8	EL2x136/40s	37	37	34	149	1.30
1 x 58 W T8	EL1x58s	48	47	34	149	1.30
2 x 58 W T8	EL2x58s	24	24	47	165	2.67
1 x 70 W T8	EL1x70s	40	40	34	149	1.30
2 x 70 W T8	EL2x70s	20	20	49	180	3.17

Lamp(s)	EL-ngn	Quantity of ballasts per miniature circuit breaker 16 A Type C		Typical inrush current I _{peak} (A)	1/2 value time Δt (μs)	Calculated energy I _{peak} ² Δt (A ² s)
		Based on I _{Cont}	Based on I _{peak}			
1 x 18 W T8	EL1x18ngn	136	74	23	131	0.51
2 x 18 W T8	EL2x18ngn	70	70	22	132	0.48
4 x 18 W T8	EL4x18ngn	36	36	37	193	2.00
1 x 36 W T8	EL1x36ngn	72	71	24	134	0.57
2 x 36 W T8	EL2x36ngn	37	37	30	152	0.90
1 x 58 W T8	EL1x58ngn	47	47	23	128	0.52
2 x 58 W T8	EL2x58ngn	24	24	50	136	2.59

Lamp(s)	EL-TCs	Quantity of ballasts per miniature circuit breaker 16 A Type C		Typical inrush current I _{peak} (A)	1/2 value time Δt (μs)	Calculated energy I _{peak} ² Δt (A ² s)
		Based on I _{Cont}	Based on I _{peak}			
1 x 9 W TC-SE	1/2x9-13TCs	229	34	41	182	0.23
1 x 10 W TC-DE	1/2x9-13TCs	224	34	41	182	0.23
1 x 10 W TC-DD	1/2x9-13TCs	215	34	41	182	0.23
1 x 11 W TC-SE	1/2x9-13TCs	167	34	41	182	0.23
1 x 13 W TC-DE/TE	1/2x9-13TCs	160	34	41	182	0.23
1 x 16 W TC-DD	1/2x9-13TCs	160	34	41	182	0.23
2 x 9 W TC-SE	1/2x9-13TCs	129	34	41	182	0.23
2 x 10 W TC-DE	1/2x9-13TCs	120	34	41	182	0.23
2 x 11 W TC-SE	1/2x9-13TCs	90	34	41	182	0.23
2 x 13 W TC-DE/TE	1/2x9-13TCs	84	34	41	182	0.23
1 x 18 W TC-DE/TE	1/2x18TCs	127	35	41	181	0.22
2 x 18 W TC-DE/TE	1/2x18TCs	67	35	41	181	0.22
1 x 21 W TC-DD	1/2x18TCs	102	35	41	181	0.22
1 x 18 W TC-L/F	1/2x18-42TCs	147	33	40	192	0.23
1 x 24 W TC-L/F	1/2x18-42TCs	96	33	40	192	0.23
1 x 26 W TC-DE/TE	1/2x18-42TCs	88	33	40	192	0.23
1 x 32 W TC-TE	1/2x18-42TCs	75	33	40	192	0.23
1 x 42 W TC-TE	1/2x18-42TCs	55	33	40	192	0.23
1 x 22 W TC-T5c	1/2x18-42TCs	96	33	40	192	0.23
1 x 40 W TC-T5c	1/2x18-42TCs	59	33	40	192	0.23
2 x 18 W TC-L/F	1/2x18-42TCs	68	33	40	192	0.23
2 x 24 W TC-L/F	1/2x18-42TCs	46	33	40	192	0.23
2 x 26 W TC-DE/TE	1/2x18-42TCs	42	33	40	192	0.23
2 x 26 W TC-DE/TE	2x32/42TCs	45	33	42	184	0.24
2 x 32 W TC-TE	2x32/42TCs	38	33	42	184	0.24
2 x 42 W TC-TE	2x32/42TCs	28	28	42	184	0.24
22 + 40 W TC-T5c	2x32/42TCs	38	33	42	184	0.24
40 + 40 W TC-T5c	2x32/42TCs	32	32	42	184	0.24

Due to our continuing program of product development data subject to change without notice.

More information at our website: <http://www.helvar.com>

Lamp(s)	EL-sc	Quantity of ballasts per miniature circuit breaker 16 A Type C		Typical inrush current I_{peak} (A)	1/2 value time Δt (μs)	Calculated energy $I_{peak}^2 \Delta t$ ($A^2 s$)
		Based on I_{Cont}	Based on I_{peak}			
1 x 14 W T5	EL1x14sc	152	86	25	49	0.26
2 x 14 W T5	EL2x14sc	83	71	31	44	0.35
4 x 14 W T5	EL4x14sc	42	42	31	44	0.35
1 x 21 W T5	EL1x21sc	107	86	25	49	0.26
2 x 21 W T5	EL2x21sc	56	56	31	44	0.35
1 x 24 W T5	EL1x24sc	99	86	25	49	0.26
2 x 24 W T5	EL2x24sc	52	52	31	44	0.35
1 x 28 W T5	EL1x28sc	83	83	25	49	0.26
2 x 28 W T5	EL2x28sc	40	40	31	44	0.35
1 x 35 W T5	EL1x35sc	66	66	31	44	0.35
2 x 35 W T5	EL2x35sc	33	33	47	149	2.43
1 x 39 W T5	EL1x39sc	61	61	31	44	0.35
2 x 39 W T5	EL2x39sc	31	31	47	149	2.43
1 x 49 W T5	EL1x49sc	48	48	31	44	0.35
2 x 49 W T5	EL2x49sc	24	24	47	205	3.37
1 x 54 W T5	EL1x54sc	43	43	31	44	0.35
2 x 54 W T5	EL2x54sc	22	22	47	205	3.37
1 x 80 W T5	EL1x80sc	29	27	47	205	3.37
1 x 18 W T8	EL1x18sc	136	86	25	49	0.26
2 x 18 W T8	EL2x18sc	70	70	31	44	0.35
4 x 18 W T8	EL4x18sc	36	34	47	149	2.43
1 x 24 W TCL	EL1x24	99	86	25	49	0.26
2 x 24 W TCL	EL2x24	52	52	31	44	0.35
1 x 36 W T8/TCL	EL1x36sc	70	70	31	44	0.35
2 x 36 W T8/TCL	EL2x36sc	36	34	47	149	2.43
1 x 58 W T8	EL1x58sc	47	47	31	44	0.35
2 x 58 W T8	EL2x58sc	24	24	47	205	3.37
1 x 70 W T8	EL1x70sc	40	34	47	149	2.43
1 x 55 W TCL	EL1x55sc	42	42	31	44	0.35
2 x 55 W TCL	EL2x55sc	22	22	47	205	3.37
1 x 80 W TCL	EL1x80sc	29	27	47	205	3.37

Lamp(s)	EL-si	Quantity of ballasts per miniature circuit breaker 16 A Type C		Typical inrush current I_{peak} (A)	1/2 value time Δt (μs)	Calculated energy $I_{peak}^2 \Delta t$ ($A^2 s$)
		Based on I_{Cont}	Based on I_{peak}			
1 x 14 W T5	EL1x14si	152	84	25	54	0.23
2 x 14 W T5	EL2x14si	83	47	34	144	1.21
4 x 14 W T5	EL4x14si	42	42	34	144	1.21
1 x 21 W T5	EL1x21si	107	84	25	54	0.23
2 x 21 W T5	EL2x21si	55	47	34	144	1.21
1 x 24 W T5	EL1x24si	92	84	25	54	0.23
2 x 24 W T5	EL2x24si	49	47	34	144	1.21
1 x 28 W T5	EL1x28si	83	83	25	54	0.23
2 x 28 W T5	EL2x28si	42	42	34	144	1.21
1 x 35 W T5	EL1x35si	66	47	34	144	1.21
2 x 35 W T5	EL2x35si	33	33	40	197	2.19
1 x 39 W T5	EL1x39si	59	47	34	144	1.21
2 x 39 W T5	EL2x39si	30	30	40	197	2.19
1 x 49 W T5	EL1x49si	48	47	34	144	1.21
2 x 49 W T5	EL2x49si	25	25	44	213	2.99
1 x 54 W T5	EL1x54si	42	42	34	144	1.21
2 x 54 W T5	EL2x54si	22	22	44	213	2.99
1 x 80 W T5	EL1x80si	29	28	44	213	2.99

EL-CHFC	Quantity of ballasts per miniature circuit breaker 16 A Type C
	Based on I_{Cont}
EL1x13CHFC3	48
EL2x13CHFC3	39
EL1x18CHFC3	48
EL2x18CHFC3	39
EL1x18-40CHFC3	48
EL2x18/24CHFC3	39
EL1x26-42CHFC3	48
EL2x26CHFC3	27
EL2x26-42CHFC3	27

EL-CHFI	Quantity of ballasts per miniature circuit breaker 16 A Type C
	Based on I_{Cont}
EL1x18CHFI	48
EL2x18CHFI	39
EL1x26-42CHFI	48
EL2x26-42CHFI	27
EL1x18-40CHFI	48
EL2x18/24CHFI	39

Wire release instructions

These instructions provide details of how to remove wires from the terminals of Helvar ballasts without damaging the terminals. Ensure mains supply is switched off before attempting any wire removal.

Magnetic ballasts

... with push in terminals

Use a 1mm² solid pin (or similar)

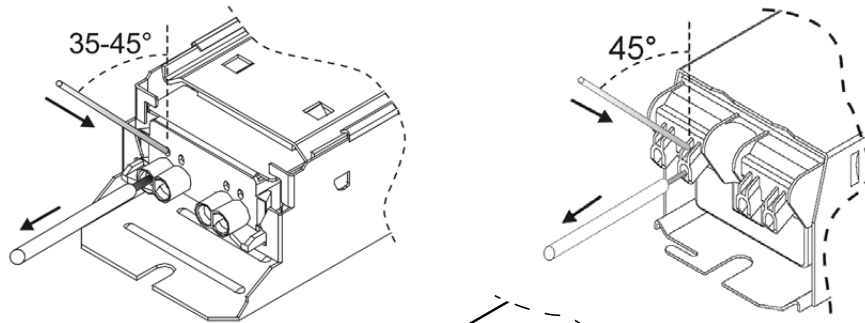

... NK/E...SE & L26S types

Use a flat blade screwdriver

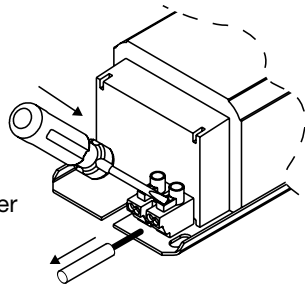

... with screw terminals

Use a flat blade screwdriver

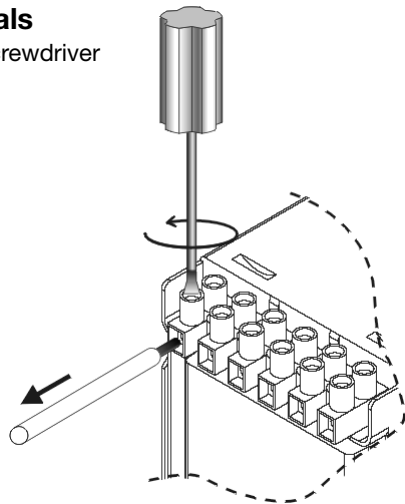

Electronic ballasts

quick release vertical push-in terminals

Use a blunt tool (example shown) to push down gently on the built in push button.

Note: Removal using a solid pin is not advised since permanent damage to the connector may occur.

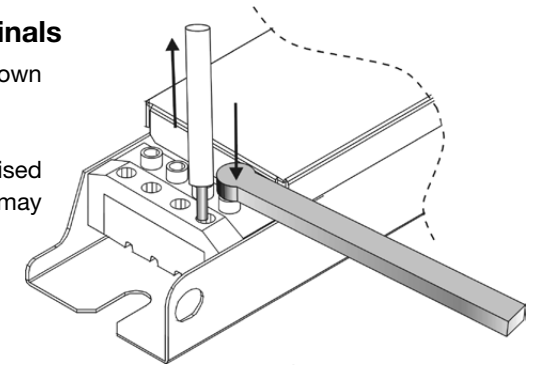

IDC & horizontal push-in terminals)

Gently twist and pull wire at the same time

Note: Wire removal from insulation piercing contact is only possible with force.

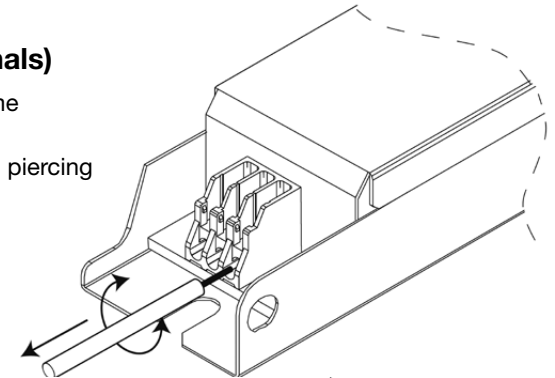

EL-ngn

Use a 1mm² solid pin (or similar) or gently twist and pull wire at the same time

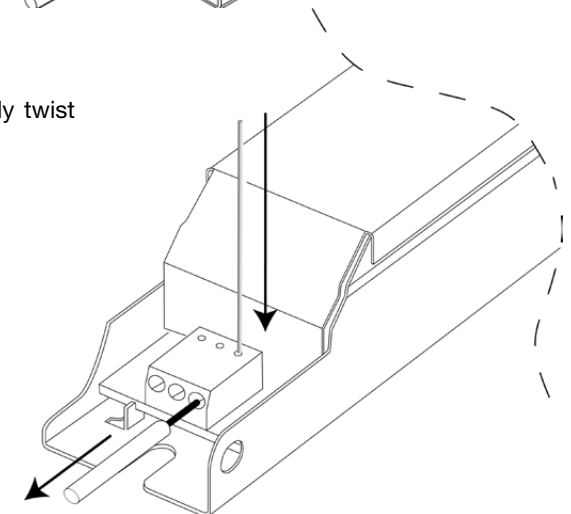





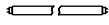
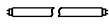



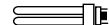

Marking	Cap	Sylvania	Osram	Philips	Thorn	Tungram	GE
---------	-----	----------	-------	---------	-------	---------	----

Fluorescent lamps



	T26 (T8)	G13	F	L	TL	F	F
	T16 (T5)	G5	F	L	TL	F	F

Compact fluorescent lamps





	TC-S	G23	LYNX-S	Dulux S	PL-S	-	FD	Biax™ S
	TC-SE	2 G 7	LYNX-SE	Dulux SE	PL-S	-	FD/E	Biax™ SE
	TC-D	G 24 d	LYNX-D	Dulux D	PL-C	-	FD-D	Biax™ D
	TC-DE	G 24 q	LYNX-DE	Dulux D/E	PL-C	-	FD-D/E	Biax™ D/E
	TC-T	GX 24 d	LYNX-T	Dulux T	PL-T	-	-	Biax™ T
	TC-TE	GX 24 q	LYNX-TE	Dulux T/E	PL-T	-	-	Biax™ T/E,QE
	TC-L	2 G 11	LYNX-L,-LE	Dulux L	PL-L	2L	FD-L	Biax™ L
	TC-DD	GR8,GR10q	-	-	-	2D	-	Biax™ 2D™
	T-R,28/30,T9	G 10 q	FC	FC	TL-E	-	-	Circline®
	T-R,16,T5	2GX13	FC	FC	TL 5 C	-	-	-
	TC-F	2 G 10	LYNX-F	Dulux F	-	-	-	-

Marking	Cap	Sylvania	Osram	Philips	Thorn	Tungram	GE
---------	-----	----------	-------	---------	-------	---------	----

High pressure mercury lamps

	HME	E27, E 40	HSL	HQL	HPL	MBF	HqLI	HqLI
	HMG	E27	-	HQL-B	HPL-B	-	-	-
	HMR	E27, E40	HSR-BW	HQL-R	HPL-R	MBFR	-	MBFR





High pressure sodium lamps

	HST	E 27, E40	SHP-T	NAV-T	SON-T	SON-T	TCF	SON-T
	HSE	E 27, E40	SHP-E	NAV-E	SON	SON-E	TCL	SON-E
	HSE-I	E 27, E40	SHP/I	NAV-E	SON	-	-	Lucalox I
	HST-DE	R 7 S, Fc 2	-	NAV-TS	-	SON-TD	-	SON-TD

Substitutive high pressure sodium lamps

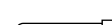
	HSE-X	E27, E 40	SHX	NAV-E	SON-H	-	-	SON-Classique
---	-------	-----------	-----	-------	-------	---	---	---------------

Metal halide lamps

	HIT	G 12	HIS-T	HQI-T	MHN-T (PG12)	MBI-T/BOH	-	MBI-T
	HIT	E 40	HIS-T	HQI-T	HPI-TD	MQI-T	HqMIF	MBIF
	HIT-DE	R 7 S, Fc 2	HIS-TD	HQI-TS	MHN-TD HPI-TD	MBIL	HqMIS	MQI
	HIT-I	E40	-	HQI-T	HPI-BUS	-	-	MBI-T
	HIE	E27, E 40	M (E27)	HQI-E	HPI	MBI	HqMIL	MBI
	HIR	E40	-	HQI-R	-	-	HqMIR	-